

AAV 980 Series C-Band VSAT Outdoor Transceiver

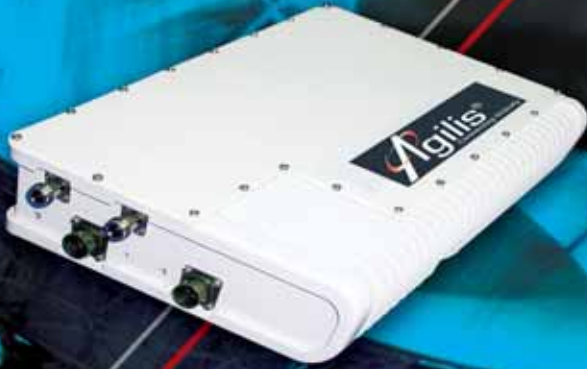

Agilis AAV 980 Series C-Band OHT (One Housing Transceiver) is a low cost RF ODU (OutDoor Unit) transceiver for satellite communication. It is designed for voice and data application operating in different modulation formats including BPSK, QPSK, QAM and FM.

Agilis AAV 980 OHT is a very compact ODU that comprises of Power Supply, Upconverter, SSPA (Solid State Power Amplifier), Downconverter and low phase noise synthesizers. It has a built-in M&C for remote and local monitoring and control. In addition, Agilis has a wide range of SSPA booster options for higher power applications.

It is suitable for SCPC (Single Channel Per Carrier) or MCPC (Multi-Channel Per Carrier), DAMA (Demand Assigned Multiple Access) and TDMA (Time Division Multiple Access) applications.

Features

- Available for all C-Band frequencies
- Broadband data transmission
- Low cost, compact model
- Easy installation & configuration
- Built-in monitor and control
- Higher power options available
- Built-in image rejection filter
- Very stable OCXO reference oscillator
- Output power monitoring
- Electronically tuneable synthesizer
- 1.0 MHz frequency step size
- Redundancy ready
- Surge protection
- 70 or 140 MHz IF interface

Applications

- Hub and VSAT terminals
- Video conferencing
- Broadcast
- Rural telephony
- Emergency link restoration
- Point-of-sales

Enhanced Monitoring and Control

Agilis AAV 980 C-OHT offers M&C via RS232/485. It features full remote M&C through Windows using PC. These include:

- Tx/Rx level monitoring
- Temperature monitoring
- RF output ON/OFF
- Frequencies selection
- Gain control
- Automatic fault identification & alarm

Reliability

Field proven under harsh environmental conditions. Agilis ODUs can withstand temperature ranging from -40°C to +60°C with up to 100% humidity.

Quality Assurance

All Agilis ODUs go through intensive active electrical stress screening with performance being monitored during screening. In addition, all units undergo 100% waterproof test equivalent to IP65 to ensure normal operation during tropical, cold and harsh environment.



TECHNICAL SPECIFICATIONS

AAV 980 Series C-Band VSAT Outdoor Transceiver

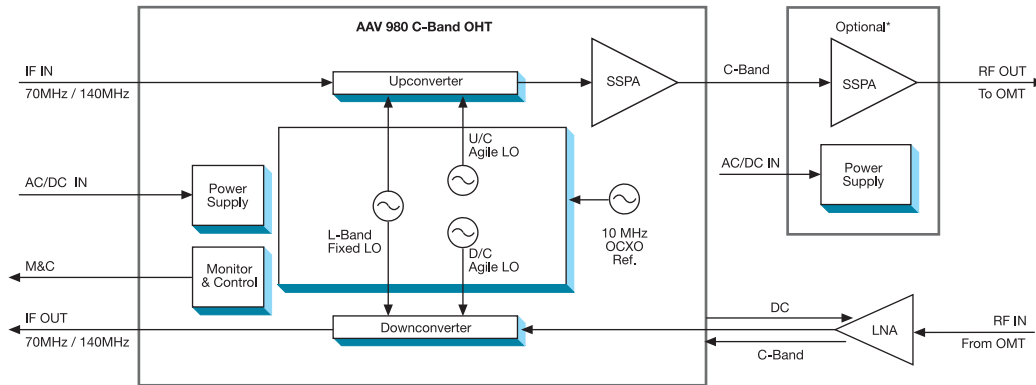

C-Band Frequency Band (GHz)

Frequency	Transmit	Receive
Intelsat	5.850 – 6.425	3.625 – 4.200
Gorizont	5.725 – 6.275	3.400 – 3.950
Insat	6.725 – 7.025	4.500 – 4.800
ST-1/ Palapa C	6.425 – 6.725	3.400 – 3.700
JCSAT	6.225 – 6.485	3.940 – 4.200

Transmit

Power	Output @P1dB (dBm) min	Min Gain (dB)	Typ AC power consumption (VA)
1mW	0	28 - 33	25
2W	33	58 - 63	50
5W	37	62 - 68	70
10W	40	65 - 70	120
20W*	43	68 - 73	200
50W*	47	72 - 77	400
80W*	49	73 - 78	700
100W*	50	75 - 80	800
150W*	51.8	77 - 82	1200
200W*	53	78 - 83	1400

Input Frequency	70±18 MHz (Optional 140 ±36 MHz)
Output Frequency	C-Band
Frequency Step Size	1.0 MHz
IF Input Power Range	-25 to -5 dBm
Gain Flatness for Full BW for 36 MHz BW	±2.0 dB max ±1.25 dB max
Gain Adjustment	20 dB@1 dB steps
Gain Stability (-40°C to +60°C)	±2.0 dB max
Spurious (36 MHz BW)	-55 dBc max
Intermodulation Product	-27 dBc max
Phase Noise @ 100Hz offset	-60 dBc/Hz
@ 1kHz offset	-70 dBc/Hz
@ 10kHz offset	-80 dBc/Hz
@ 100kHz offset	-90 dBc/Hz
Input / Output VSWR	1.5 : 1 max
IF Input / RF Output Interface	50Ω N-type Female
Frequency Stability	±0.5 ppb/day

Power Supply

Input Voltage (Factory Preset)	220Vac, 110Vac or 48Vdc
DC Output Voltage to LNA	+12Vdc at RF IN Connector

Compliance Standard

IEC 60950	International Safety Standard for Information Technology Equipment
ETSI EN 300 673	Electromagnetic Compatibility and Radio Spectrum Matters (ERM); ElectroMagnetic Compatibility (EMC) Standard for Very Small Aperture Terminal (VSAT)
ETSI EN 301 489-1	Electromagnetic Compatibility and Radio Spectrum Matters (ERM); ElectroMagnetic Compatibility Standard for Radio Equipment and Services

Environmental

Operating Temperature	-40°C to +60°C
Relative Humidity	up to 100%

Low Noise Amplifier

Input Frequency	C-Band
Noise Temperature at 25°C	35°K typ
Gain	55 dB typ
Gain Flatness (36 MHz BW)	±0.20 dB max
Input VSWR	2.5 : 1
Output VSWR	1.7 : 1
RF Input Interface	WR229/G
RF Output Interface	50Ω N-type Female

Receive (exclude LNA)

Input Frequency	C-Band
Output Frequency	70±18 MHz (Optional 140±36 MHz)
Frequency Step Size	1.0 MHz
Gain	45 dB min
Gain Flatness for Full BW for 36 MHz BW	±3.0 dB max ±1.25 dB max
Gain Stability (-40°C to +60°C)	±3.0 dB max
Spurious (36 MHz BW)	-55 dBc max
Intermodulation Product	-35 dBc max
Phase Noise @ 100Hz offset	-60 dBc/Hz
@ 1kHz offset	-70 dBc/Hz
@ 10kHz offset	-80 dBc/Hz
@ 100kHz offset	-90 dBc/Hz
Input / Output VSWR	1.5 : 1 max
RF Input / IF Output Interface	50Ω N-type Female
Frequency Stability	±0.5ppb/day
Gain Adjustment	25 dB @ 1dB step

Monitor And Control

Interface	RS 232/485
Form 'C' Relay Contacts	Optional

Mechanical

Dimensions	340L x 255W x 70H mm	(1mW, 2W, 5W OHT)
	410L x 175W x 275H mm	(10W, 20W Booster)
	342L x 278W x 173H mm	(50W Booster)
	420L x 290W x 290H mm	(80W, 100W, 150W, 200W Booster)
Weight	7.0 kg	(1mW, 2W, 5W, 10W OHT)
	13.0 kg	(20W Booster)
	18.0 kg	(50W Booster)
	23.5 kg	(100W to 150W Booster)
	40.0 kg	(200W to 250W Booster)
Colour	White Powder Coat	

* Booster with 1mW driver

Note: All specifications are subject to changes without notice.