

# AAV 628 Series Ku-Band VSAT Outdoor Transceiver



Agilis AAV 628 Series Ku-Band SPT (Ku-Band Single Package Transceiver) is a highly cost effective RF ODU (Outdoor Unit) transceiver for satellite communication. It is designed for voice, data and broadband VSAT communication used in different modulation formats including BPSK, QPSK, QAM and FM.

Agilis AAV 628 SPT is a highly integrated ODU that comprises of Upconverter, SSPA (Solid State Power Amplifier), Downconverter, low phase noise synthesizer, power supply and built-in M&C. With independent frequency synthesizer, it enables end-users for transmission through different uplink and downlink transponders. In addition, Agilis has a wide range of SSPA booster options for higher power applications.

Agilis AAV 628 SPT is suitable for SCPC (Single Channel Per Carrier), MCPC (Multi-Channel Per Carrier), DAMA (Demand Assigned Multiple Access) or TDMA (Time Division Multiple Access) applications.

## Features

- Available for all Ku-Band frequencies
- Broadband data transmission
- Easy installation & configuration
- Built-in monitor and control
- Higher power options available
- Built-in image rejection filter
- Very stable OCXO reference oscillator
- Output power monitoring
- Electronically tuneable synthesizer for Transmit and Receive
- 1.0 MHz frequency step size
- Redundancy ready
- Surge protection
- 70 or 140 MHz IF interface

## Applications

- Hub and VSAT terminals
- Video conferencing
- Broadcast
- Rural telephony
- Emergency link restoration
- Point-of-sales

## Enhanced Monitoring and Control

AAV 628 Ku-SPT offers M&C via RS232/485. It features full remote M&C through Windows using PC.

These include:

- Tx/Rx level monitoring
- Temperature monitoring
- RF output ON/OFF
- Frequencies selection
- Gain control
- Automatic fault identification & alarm

## Reliability

Field proven under harsh environmental conditions. Agilis ODUs can withstand temperature ranging from -40°C to +60°C with up to 100% humidity.

## Quality Assurance

All Agilis ODUs go through intensive active electrical stress screening with performance being monitored during screening. In addition, all units undergo 100% waterproof test equivalent to IP65 to ensure normal operation during tropical, cold and harsh environment.



# TECHNICAL SPECIFICATIONS

# AAV 628 Series Ku-Band VSAT Outdoor Transceiver

Ku-Band  
Transceiver

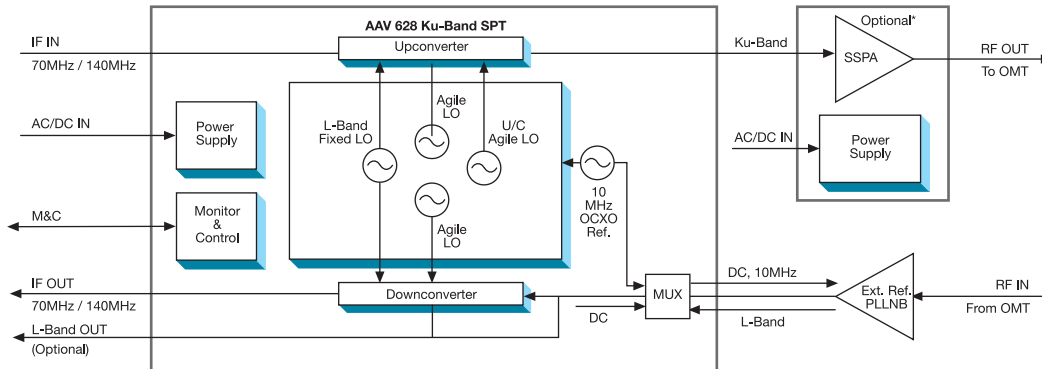

## Ku-Band Frequency Band (GHz)

<b>Transmit</b>	13.75 - 14.25 (Offset)
	14.00 - 14.50 (Standard)
	13.75 - 14.50 (Extended)
<b>Receive</b>	10.95 - 11.70
	11.70 - 12.20
	12.25 - 12.75

## Transmit

Power	Output @P1dB (dBm) min	Min Gain (dB)	Typ AC power consumption (VA)
2W	33	58 - 63	100
4W	36	61 - 66	150
8W	39	64 - 69	150
16W*	42	67 - 72	250
25W*	44	69 - 73	300
40W*	46	71 - 76	600
80W*	49	74 - 79	1000

<b>Input Frequency</b>	70±18 MHz (Optional 140±36 MHz)
<b>Output Frequency</b>	Ku-Band
<b>Frequency Step Size</b>	1.0 MHz
<b>IF Input Power Range</b>	-25 to -5 dBm
<b>Gain Flatness for 500MHz BW</b>	±2.0 dB max
<b>for 36MHz BW</b>	±1.25 dB max
<b>Gain Stability (-40°C to +60°C)</b>	±2.0 dB max
<b>Gain Adjustment</b>	20 dB @ 0.5 dB steps
<b>Intermodulation Product (with 2 carriers at 3dB OPBO composite power)</b>	-25 dBc max
<b>Spurious (36 MHz BW)</b>	-55 dBc max
<b>Phase Noise @ 100Hz offset</b>	-60 dBc/Hz
<b>@ 1 kHz offset</b>	-70 dBc/Hz
<b>@ 10kHz offset</b>	-80 dBc/Hz
<b>@ 100kHz offset</b>	-90 dBc/Hz
<b>IF Input Interface</b>	50Ω N-type Female
<b>RF Output Interface</b>	WR75/G
<b>Frequency Stability</b>	±0.5 ppb/day

## Monitor And Control

<b>Interface</b>	RS 232/485
<b>Form 'C' Relay Contacts</b>	Optional

## Compliance Standard

<b>IEC 60950</b>	International Safety Standard for Information Technology Equipment
<b>ETSI EN 300 673</b>	Electromagnetic Compatibility and Radio Spectrum Matters (ERM); ElectroMagnetic Compatibility (EMC) Standard for Very Small Aperture Terminal (VSAT)
<b>ETSI EN 301 489-1</b>	Electromagnetic Compatibility and Radio Spectrum Matters (ERM); ElectroMagnetic Compatibility Standard for Radio Equipment and Services

## Environmental

<b>Operating Temperature</b>	-40°C to +60°C
<b>Relative Humidity</b>	up to 100%

## Receive (exclude LNB)

<b>Input Frequency</b>	950 to 1450 MHz (Optional 900 to 1700 MHz)
<b>Output Frequency</b>	70±18 MHz (Optional 140±36 MHz)
<b>Output Frequency (Optional)</b>	950 to 1450 MHz
<b>Output Power@ P1dB</b>	0 dBm min
<b>Frequency Step Size</b>	1.0 Mhz
<b>Gain</b>	25 dB min
<b>Gain Adjustment</b>	20 dB @ 1dB steps
<b>Gain Flatness (36 MHz BW)</b>	±1.25 dB max
<b>Gain Stability (-40°C to +60°C)</b>	±3.0 dB max
<b>Intermodulation Product</b>	-35 dBc max
<b>Spurious (36 MHz BW)</b>	-55 dBc max
<b>Phase Noise @ 100Hz offset</b>	-60 dBc/Hz
<b>@ 1 kHz offset</b>	-70 dBc/Hz
<b>@ 10kHz offset</b>	-80 dBc/Hz
<b>@ 100kHz offset</b>	-90 dBc/Hz
<b>Input Interface</b>	50Ω N-type Female
<b>Output Interface</b>	50Ω N-type Female

## Power Supply

<b>Input Voltage (Factory Preset)</b>	220Vac (Optional 110Vac, 48Vdc)
<b>DC Output Voltage to LNB</b>	+13Vdc at RF IN connector

## Phase Locked Low Noise Block (PL LNB)

<b>Input Frequency</b>	Ku-Band
<b>Output Frequency</b>	950 to 1700 MHz
<b>Noise Figure / Temperature at +25°C</b>	1.0 dB / 75°K
<b>Gain</b>	58 dB typ
<b>Gain Flatness (36 MHz BW)</b>	±0.25 dB max
<b>External Reference</b>	10 MHz
<b>Input Interface</b>	WR75/G
<b>Output Interface</b>	50Ω N-type Female

## Mechanical

<b>Dimensions</b>	310L x 240W x 98H mm	(2W, 4W, 8W SPT)
	342L x 235W x 204H mm	(16W, 25W Booster)
	525L x 285W x 275H mm	(40W Booster)
	610L x 432W x 254H mm	(80W Booster)
<b>Weight</b>	7.5 kg	(2W, 4W, 8W SPT)
	15.0 kg	(16W, 25W Booster)
	20.0 kg	(40W Booster)
	35.0 kg	(80W Booster)
<b>Colour</b>	White Powder Coat	

\* Booster with 2W driver  
Note: All specifications are subject to changes without notice.